

**BK: 2020 PG: 36133**  
**Recorded: 12/21/2020 at 8:04:36.0 AM**  
**County Recording Fee: \$112.00**  
**Iowa E-Filing Fee: \$5.09**  
**Combined Fee: \$117.09**  
**Revenue Tax:**  
**Chad C. Airhart Recorder**  
**Dallas County, Iowa**

Prepared by and when recorded return to: Stuart Ruddy, c/o Knapp Properties, L.C., 5000 Westown Parkway, Suite 400 West Des Moines, Iowa, 50266 (515) 223-4000

---

**FIRST AMENDMENT TO MASTER DECLARATION OF COVENANTS,  
CONDITIONS AND RESTRICTIONS**

THIS FIRST AMENDMENT TO MASTER DECLARATION (hereinafter "First Amendment") is made this 18<sup>th</sup> day of December 2020, by **RACCOON RIVER LAND CO., L.L.C.**, an Iowa limited liability company (the "Declarant").

**WHEREAS**, Declarant adopted the Master Declaration of Covenants, Conditions and Restrictions dated November 6, 2020 and recorded on November 19, 2020 at Book 2020 Page 32931 of the Dallas County Recorder's office ("Master Declaration"), such Master Declaration governing the use of the property defined in the Master Declaration as the Development Area; and

**WHEREAS**, Declarant is the owner of all lots in the Development Area ; and

**WHEREAS**, Declarant is desirous of amending the Master Declaration as more particularly set forth below.

**NOW, THEREFORE**, Declarant hereby amends the above-described Master Declaration as follows:

1. Paragraph I.A is deleted in its entirety and replaced with the following new paragraph I.A:

"Association" shall mean and refer to Preserve Owners Master Association, its successors and assigns, a non-profit corporation organized pursuant to Chapter 504 of the Code of Iowa as amended.

2. Paragraph I.B is deleted in its entirety and replaced with the following new paragraph I.B:

"Association Board" shall mean the board of directors of the Preserve Owners Master Association.

3. Paragraph IX entitled Landscaping is deleted in its entirety and replaced with the following new paragraph IX:

Lot landscaping shall be the responsibility of the Owner and shall reflect one or more of the landscape patterns recommended for the type of Lot in the Pattern

Book. Additionally, the amount of lot landscaping specified in the Pattern Book shall be strictly adhered to by the Owner. Frontage street trees as shown on the final plat construction plans shall be included on the dwelling landscape plans and installed with the Lot landscaping or upon installation of the sidewalks. All landscaping must be installed within six (6) months from the completion of construction. All landscaping shall be maintained and replaced (as necessary) by the Owner in conformance with the standards of the Pattern Book.

The Owner shall keep the Lot free of debris and shall keep the grass mowed so that it does not exceed six inches in height.

All Common Area landscaping conditions shall conform with the guidelines in the Pattern Book referenced herein as Exhibit 1.

4. Paragraph XI entitled Architectural Review is deleted in its entirety and replaced with the following new paragraph XI:

“The Architectural Review Board shall review plans and specifications for all proposed buildings, structures, outbuildings, and any such other requests as it relates to the Development Area. The Architectural Review Committee shall be responsible for matters covered by this Master Declaration which may not be covered by a separate declaration for those certain developments located within the Preserve. The Architectural Review Board of the Association and the Declarant shall have the right to delegate any responsibilities for the review and approval of plans to the Subassociation or neighborhood association through a separate declaration and shall have the right to approve any signage revisions under this Master Declaration.”

5. Paragraph XXV entitled Disclaimer is deleted in its entirety and replaced with the following new paragraph XXV:

“Declarant may at any time by written instrument filed with the Dallas County Recorder, disclaim their rights and powers hereunder and thereafter it shall have no rights or responsibilities hereunder. Declarant shall have no liability in or for damages of any sort to any Owner, or nay lessee or occupant of any Lot, or otherwise to any person for any exercise or failure to exercise any right (or duty or obligation, if any) of Declarant hereunder, for the making of an amendment or modification hereto by Declarant for the granting of approval or withholding of approval required or permitted under the terms of this Master Declaration or in any other manner arising herefrom. Provided however, any Owner may exercise any rights such Owner may have against Declarant or otherwise seek to enforce the provisions of this Master Declaration against Declarant by an action in equity for specific performance or injunctive relief to which Declarant shall be subject. The remedies of specific performance and injunctive relief shall be the only remedies against Declarant hereunder, for the making of an amendment or modification hereto by Declarant, for the granting of approval or withholding of approval required or permitted under the terms of this Master Declaration or for other matters arising herefrom, all other remedies being expressly waived.

Notwithstanding the foregoing, the rights and powers of the Declarant hereunder shall be deemed to have been disclaimed by Declarant five (5) years following the date on which Declarant conveys the last Lot it owns in the Property, and thereafter enforcement of this Master Declaration may be carried out exclusively by the Owners as provided in Article XIX, above.”

All other terms and conditions of the Master Declaration shall remain the same.

**IN WITNESS WHEREOF**, Declarant has caused this First Amendment to be executed on the date listed above.

[SIGNATURES ON THE FOLLOWING PAGE]

**RACCOON RIVER LAND CO., L.L.C.**  
an Iowa limited liability company

By: William C. Knapp, L.C.  
an Iowa limited liability company  
Managing Member

By: *Gerard D. Neugent*  
Gerard D. Neugent, Manager

By: RACCOON RIVER INVESTORS, LLC  
Managing Member

By: JSC TRUST  
Member

By: *Paul D. Hayes*  
Paul D. Hayes, Trustee

**ACKNOWLEDGEMENTS**

State of Iowa )  
)ss:  
County of Polk )

This record was acknowledged before me on December 18, 2020 by Gerard D. Neugent, Manager of William C. Knapp, L.C., Member of Raccoon River Land Co., L.L.C.

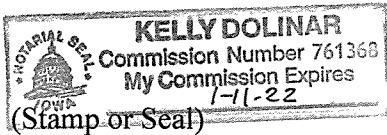

*Kelly Dolinar*  
Notary Public

State of Iowa )  
)ss:  
County of Polk )

This record was acknowledged before me on December 18, 2020 by Paul D. Hayes, Trustee of JSC Trust, Member in Raccoon River Investors, LLC, Member of Raccoon River Land Co., L.L.C.

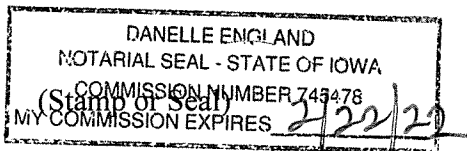

*Danelle England*  
Notary Public

**EXHIBIT 1 - PATTERN BOOK**

On the following page



SIGNAGE & IDENTITY PACKAGE



SHIVHATTERY  
ARCHITECTURE+ENGINEERING

2020 . 03 . 10

## SIGN FAMILY

The materials palette of weathered steel and stone is the common thread through all signage features as well as a consist graphic, typographic, and color palette. The use of native plant materials is also planned as a visual tie between the multiple elements in the identity package.

The intent is to achieve the look of natural materials - corten steel and limestone. This can be achieved with other standard sign materials, paint/coating techniques, veneers, etc. Contractor is encouraged to explore cost effective ways to achieve the design intent.

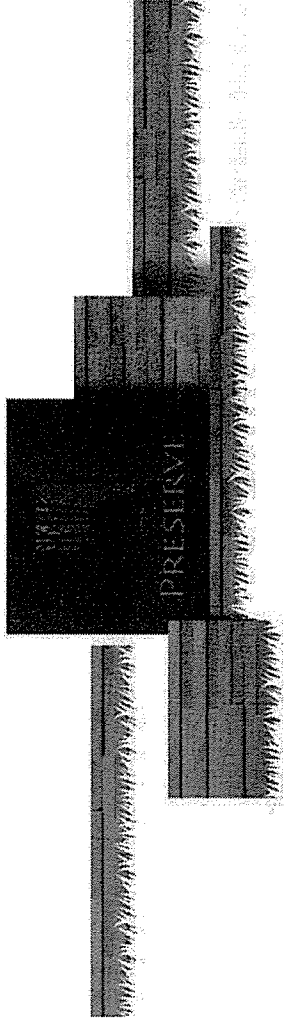

PRIMARY ENTRANCES

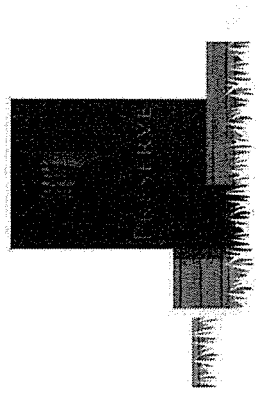

SECONDARY ENTRANCES

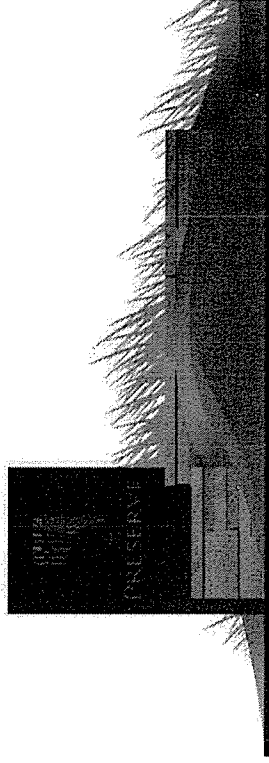

GATEWAYS

## THE PRESERVE IDENTITY SIGNAGE PACKAGE

MARCH 10 . 2020

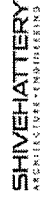

SIGN FAMILY



MARKERS

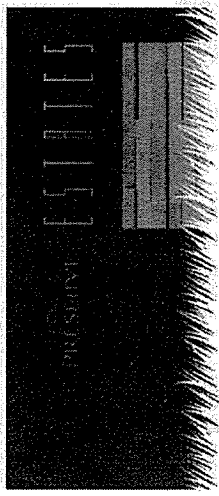

NEIGHBORHOODS

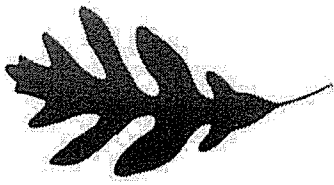

SCULPTURAL ACCENTS

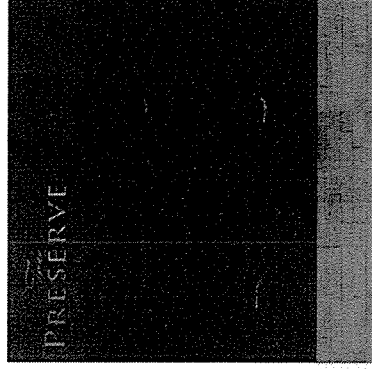

COMMERCIAL

THE PRESERVE IDENTITY SIGNAGE PACKAGE

MARCH 10 . 2020

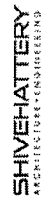



## PRIMARY ENTRANCE

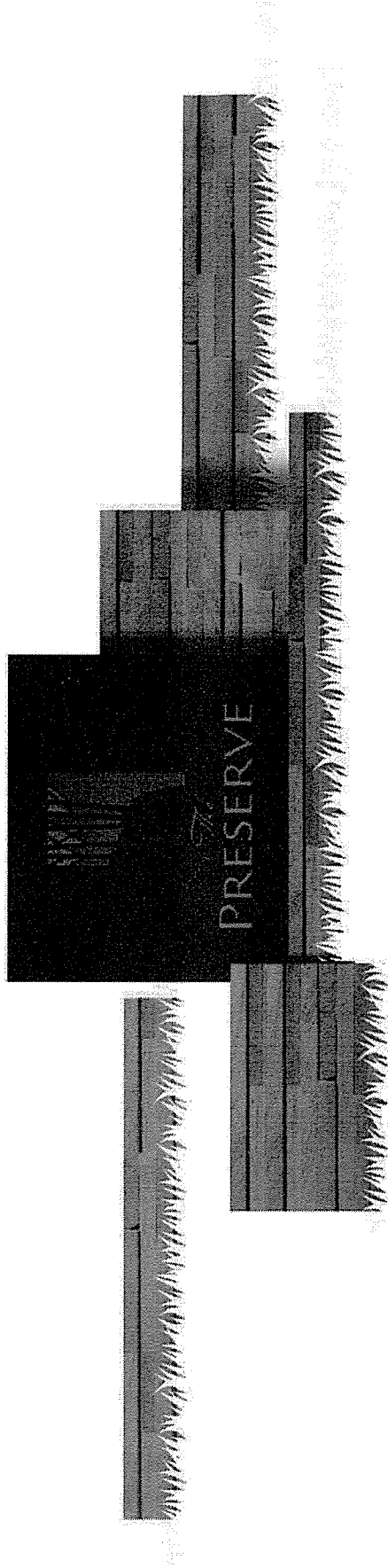

Painted metal sign faces with 'Preserve' logo routed and backed with colored lexan

'The Preserve': push-through acrylic lettering with translucent metallic face.

Wall: smooth limestone layered in tiers, arranged in multiple columns. Columns are embedded into berm which is planted in native grasses.

THE PRESERVE IDENTITY SIGNAGE PACKAGE

MARCH 10 . 2020



SHIVEHATTERY  
ARCHITECTURE + INTERIORS

PRIMARY ENTRANCE

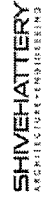
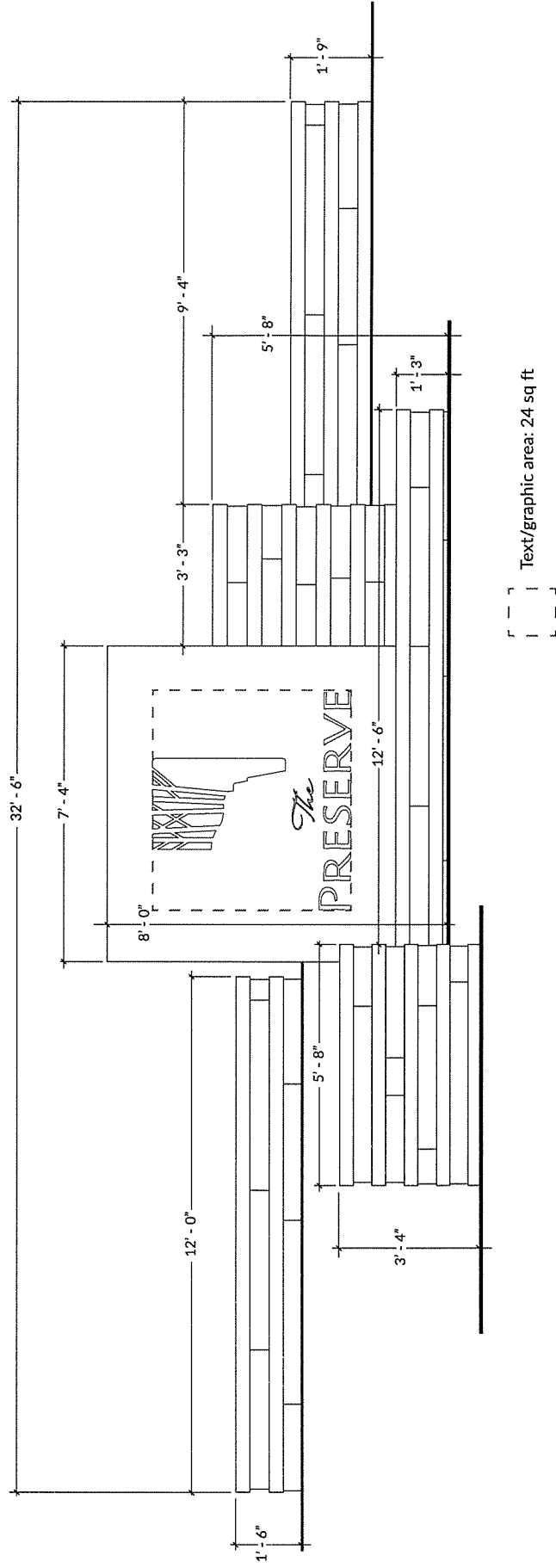

PRIMARY ENTRANCE

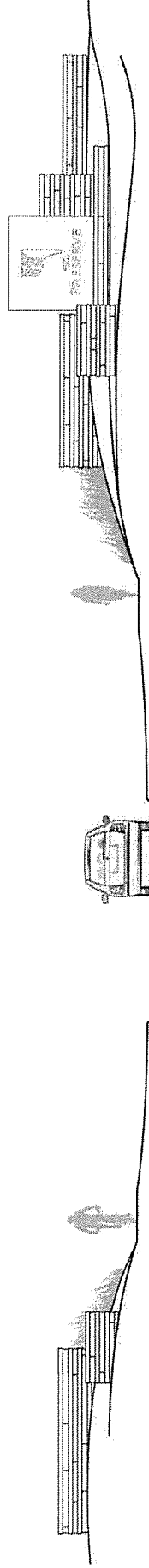
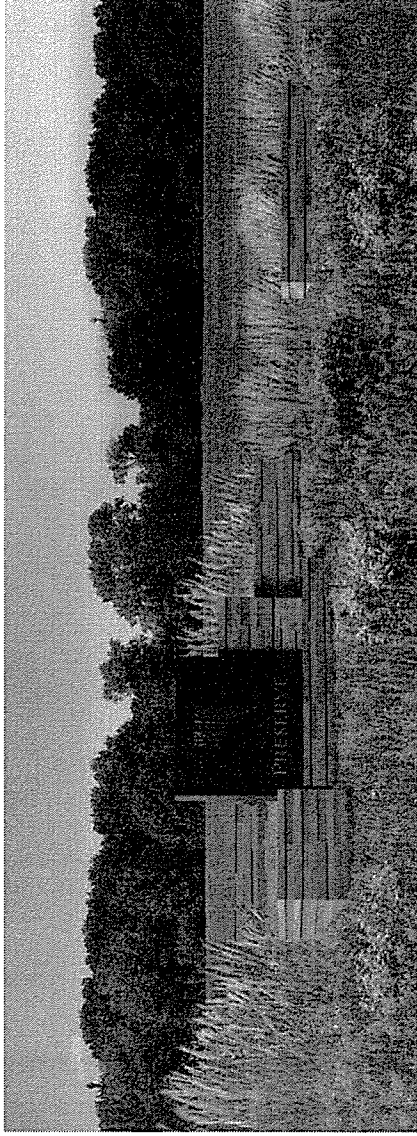

THE PRESERVE IDENTITY SIGNAGE PACKAGE

MARCH 10, 2020



SHIVEHATTERY  
ARCHITECTURE-ENGINEERING

## ENTRANCE SIGNAGE ILLUMINATION

Painted metal sign faces with 'Preserve' logo routed and backed with colored lexan

'The Preserve': push-through acrylic lettering with translucent metallic face.

Wall: smooth limestone layered in tiers, arranged in multiple columns. Columns are embedded into berm which is planted in ornamental grasses.

Signage will be internally illuminated, stone features will be uplit.

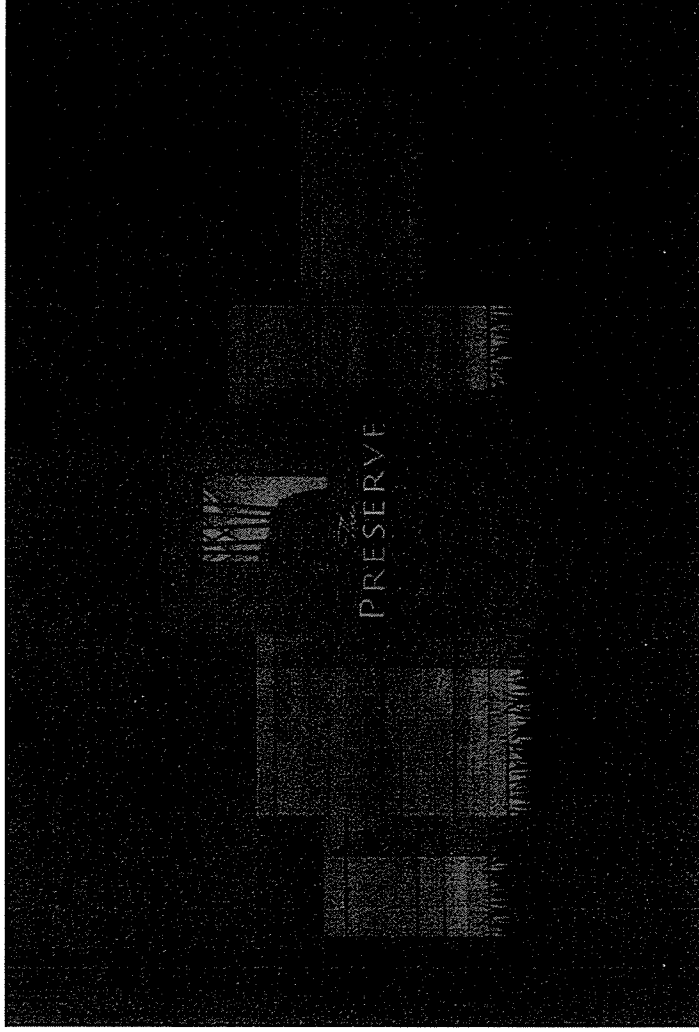

THE PRESERVE IDENTITY SIGNAGE PACKAGE

MARCH 10 . 2020



SHIVEHATTERY  
ARCHITECTURE + ENGINEERING

## SECONDARY ENTRANCE

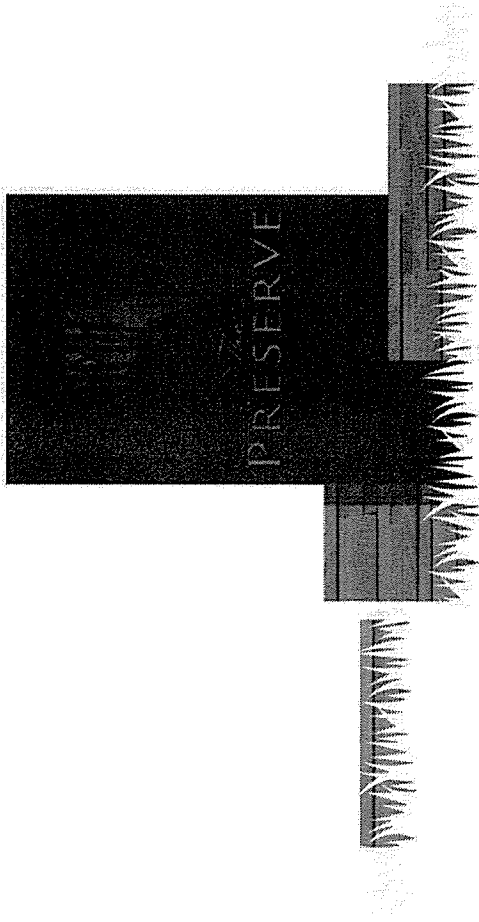

Painted metal sign faces with 'Preserve' logo routed and backed with colored lexan

'The Preserve': push-through acrylic lettering with translucent metallic face.

Wall: smooth limestone layered in tiers, arranged in multiple columns. Columns are embedded into berm which is planted in ornamental grasses.

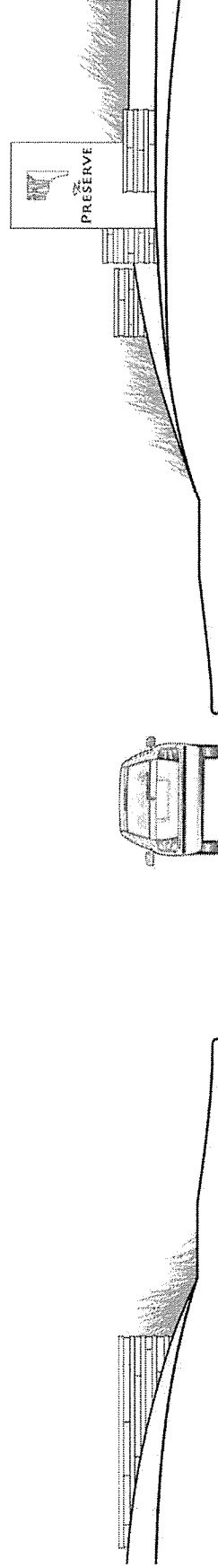

SECONDARY ENTRANCE

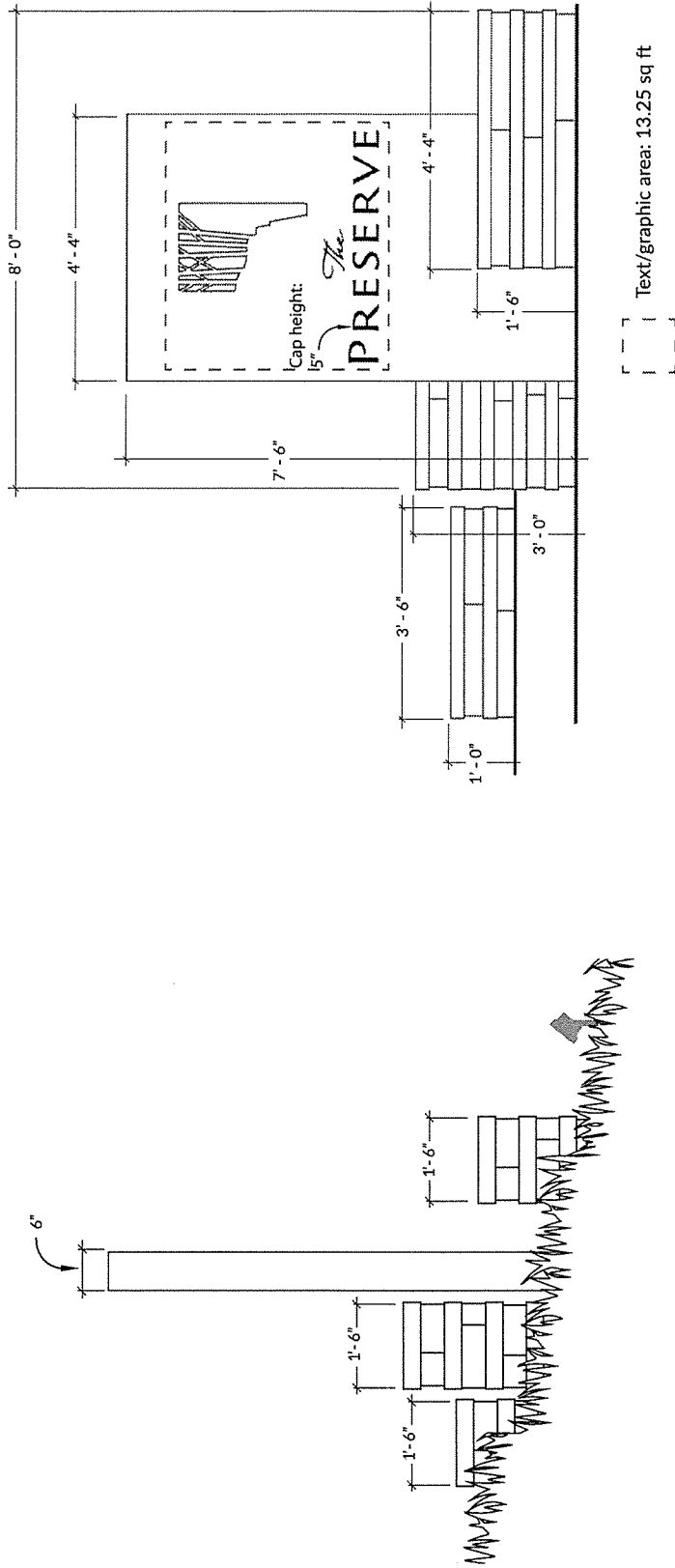

SHIVEHATTERY  
ARCHITECTURAL ENGINEERING

## GATEWAYS

Painted metal sign faces with 'Preserve' logo routed and backed with colored lexan

'The Preserve'; push-through acrylic lettering with translucent metallic face.

Smooth limestone column in layered tiers. Columns are placed in a bermed landscape planted in ornamental grasses.

Signage will be internally illuminated, stone features will be uplit.

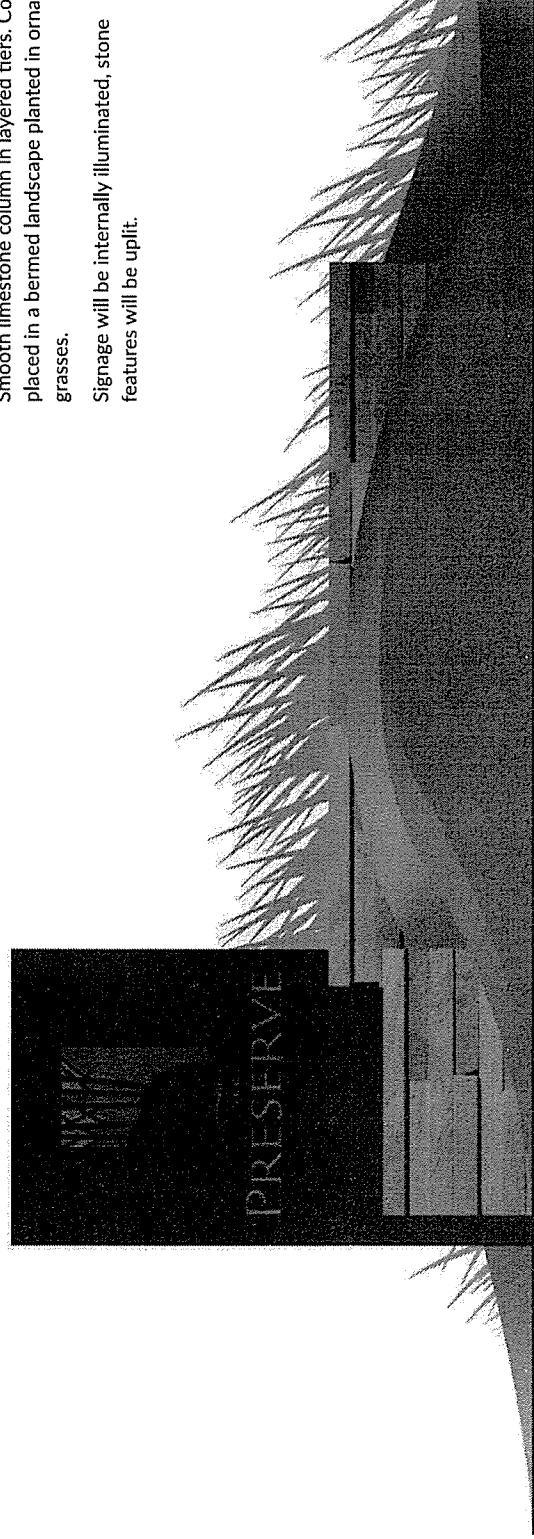

**GATEWAYS**

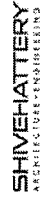
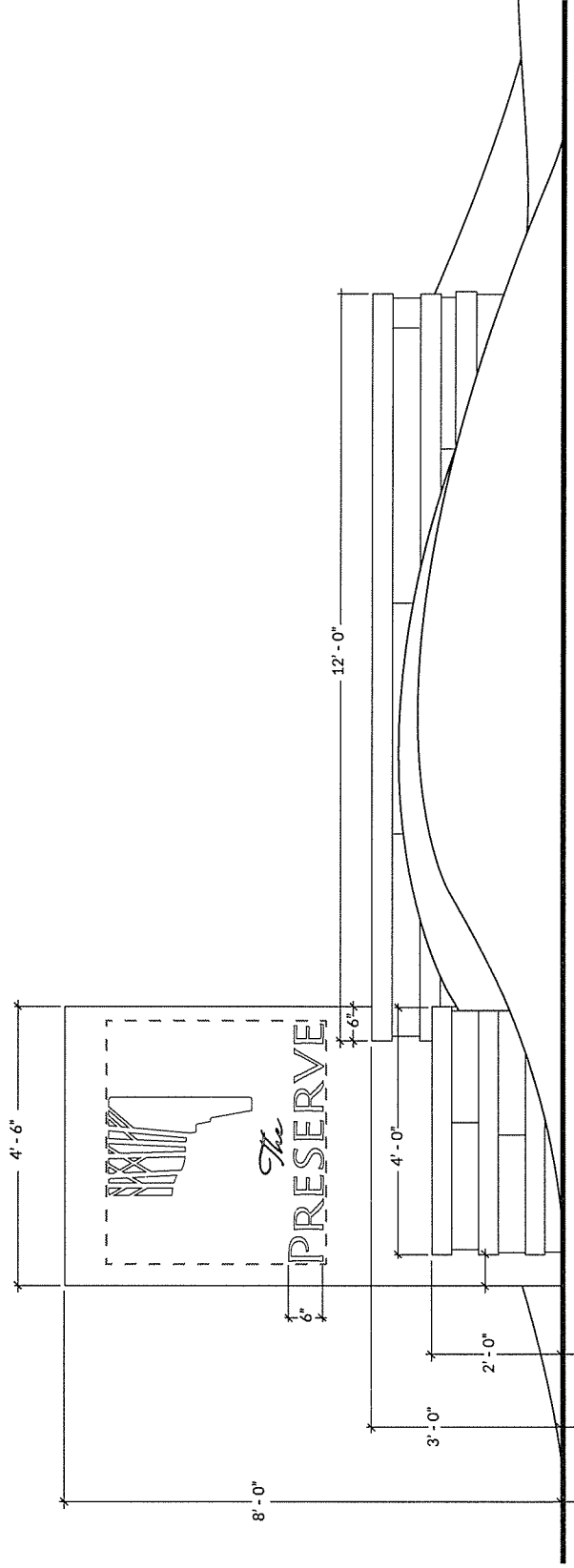



## BOUNDARY MARKERS

Painted metal sign faces with branch motif routed and backed with colored lexan.

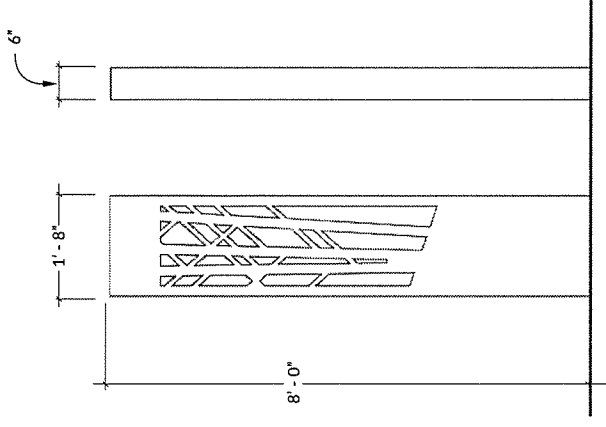
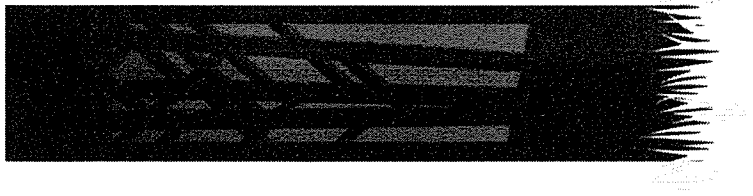

THE PRESERVE IDENTITY SIGNAGE PACKAGE

MARCH 10 . 2020



SHIVEHATTERY  
ARCHITECTURE + ENGINEERING

**NEIGHBORHOOD IDENTIFIERS**

Painted metal sign faces with branch motif.

Graphic customized for each neighborhood.

Accented with stone and ornamental grasses.

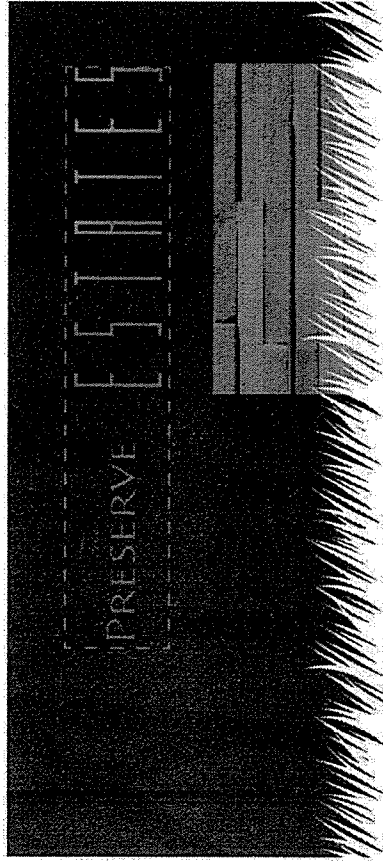

[ ] Text/graphic area: 6 sq ft

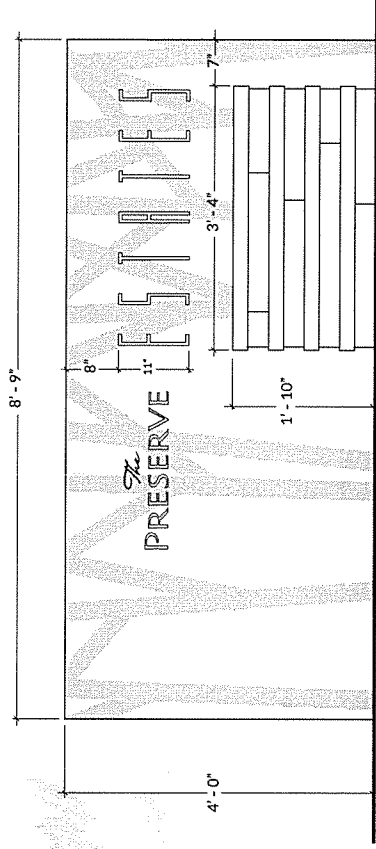

## SCULPTURAL ACCENTS

Cut metal sculptures mounted in berms among native vegetation planting.

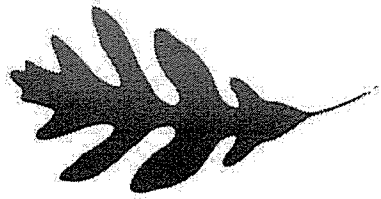
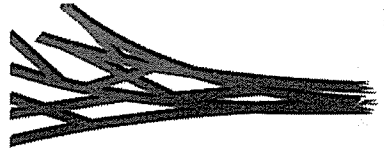

THE PRESERVE IDENTITY SIGNAGE PACKAGE

MARCH 10, 2020



SHIVEHATTERY  
ARCHITECTURAL CONSULTING

**COMMERCIAL SIGNAGE**

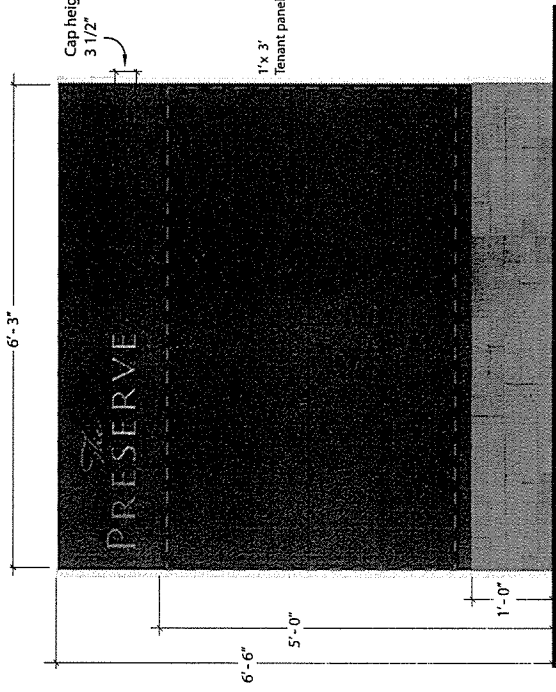

Multiple tenants

Text/graphic area: 24 sq ft per side

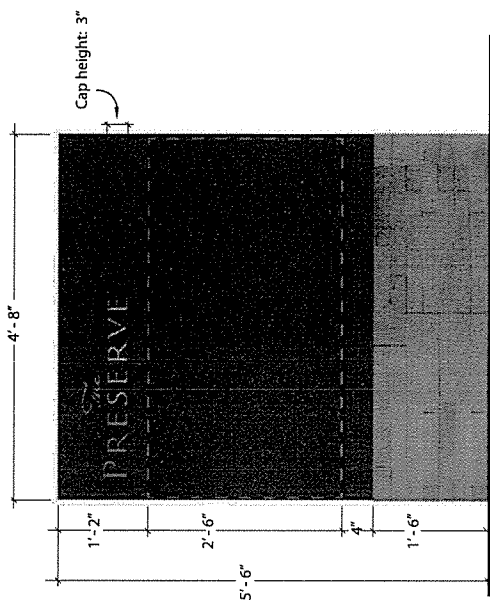
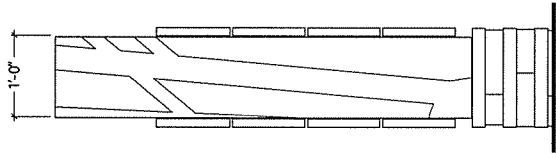

Single tenant

"The Preserve"; push-through acrylic with translucent metallic face.  
 Cabinet painted with enlarged tree motif.  
 Cabinet constructed with removable tenant panels, internally illuminated.





**PROPOSED SIGN LOCATIONS**

-  PRIMARY ENTRANCE
-  SECONDARY ENTRANCE
-  GATEWAYS
-  NEIGHBORHOODS (Locations will vary)
-  MARKER ZONES
-  SCULPTURE



LOGO / IDENTITY

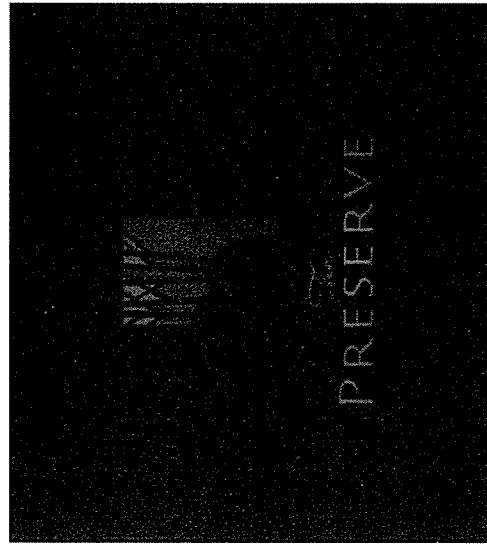

PMS 7584

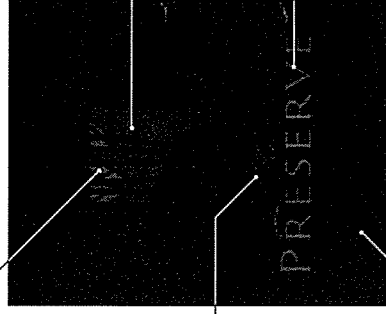

PMS 7593

PMS 7593

PMS 7584

PMS Black 5



*The*  
**PRESERVE**

THE PRESERVE IDENTITY SIGNAGE PACKAGE

MARCH 10 . 2020



**SHIVEHATTERY**  
ALERTING TOGETHER. INSPIRING.

**BK: 2020 PG: 32931**  
**Recorded: 11/19/2020 at 2:29:00.0 PM**  
**County Recording Fee: \$62.00**  
**Iowa E-Filing Fee: \$4.16**  
**Combined Fee: \$66.16**  
**Revenue Tax:**  
**Chad C. Airhart Recorder**  
**Dallas County, Iowa**

Prepared by and when recorded return to: Stuart Ruddy, c/o Knapp Properties, L.C., 5000 Westown Parkway, Suite 400 West Des Moines, Iowa, 50266 (515) 223-4000

---

**MASTER DECLARATION OF COVENANTS, CONDITIONS AND RESTRICTIONS**

THIS MASTER DECLARATION (hereinafter "Master Declaration") is made this 6<sup>th</sup> day of November 2020, by **RACCOON RIVER LAND CO., L.L.C.**, an Iowa limited liability company (the "Declarant").

**WHEREAS**, Declarant is the owner of certain property depicted as follows:

See Exhibit "A", attached hereto and incorporated herein by reference.

**WHEREAS**, Parcels within the Exhibit A (hereinafter "Development Area") are zoned and/or designated for various residential, office, commercial and/or mixed uses, and will be developed at various and uncertain times in the present and future ;and

**WHEREAS**, Declarant desires to record the plats of the Preserves (the "Plats"), for the Development Area to facilitate such development and understand and acknowledge the execution and recording of this Master Declaration is a condition precedent to the final approval of such Plats by the City of West Des Moines, Iowa (the "City"); and

**WHEREAS**, Declarant, and its successors and assigns, desire to provide for the dedication of and future construction of public sidewalks and other common areas in the Development Area and provide for the cost of maintaining, repairing and replacing certain landscaping, signage, irrigation systems, sidewalks and/or trails, private drives, parking areas, fences, walls, hedges, poles and berm areas within the Development Area (hereinafter "Common Areas"), until all future City approvals are obtained related to the platting of the Development Area, which obligations shall be binding upon Declarant and its respective successors and assigns, and which shall run with the land and each part thereof, all as set forth in this Master Declaration.

**NOW, THEREFORE**, Declarant, by execution and recording of this Master Declaration, hereby declares that the Development Area and all Plats referenced herein, shall be held, occupied, sold and conveyed subject to easements, covenants, protective conditions, restrictions and reservations set forth in this Master Declaration:

## **I. DEFINITIONS.**

For the purpose of this Master Declaration, the following terms shall have the following definitions, except as otherwise specifically provided:

- A. "Association" shall mean and refer to Preserve Owners Master Association, Inc., its successors and assigns, a non-profit corporation organized pursuant to Chapter 504 of the Code of Iowa as amended.
- B. "Association Board" shall mean the board of directors of the Preserve Owners Master Association, Inc.
- C. "Builder" shall mean and refer to one or more persons or entities that construct a dwelling or outbuilding within the Development Area.
- D. "City" shall mean the city of West Des Moines, Iowa.
- E. "Common Areas" shall mean and refer to all portions of the Preserve now or hereafter owned by the Declarant or Association from time to time designated or declared by Declarant for the common use and enjoyment of the Owner. Included within the Common Areas but not limited to the following, are any maintenance areas, parking lots, walkways, sidewalks, detention ponds, storm water improvements, lakes, recreational areas, street lighting, and signage
- F. "Declarant" shall mean and refer to Raccoon River Land Co., L.L.C., an Iowa limited liability company, and its successors and assigns.
- H. "Owner" shall mean and refer to the record owner or occupant of any lot within the Development Area.
- I. "Pattern Book" shall mean the Plats designated Pattern Book that establishes requirements and guidelines for neighborhood character, building design and landscape elements within the Development Area.
- J. "Subassociation" shall mean the neighborhood associations or neighborhood associations within the Preserve which are subordinate to the Association.

## **II. RESIDENTIAL AND COMMERCIAL USE**

Declarant, on behalf of itself and its successors and assigns, hereby covenant and agree that no development shall occur within the Plat unless and until further subdivision plats, and other necessary approvals are obtained from the City in accordance with City ordinances.

## **III. BUILDING TYPES.**

Permitted residential building types shall be only those specified in the Pattern Book.

No mobile home or manufactured home as defined in the Code of Iowa shall be placed or erected on any Lot. No dwelling structure of any kind may be moved onto any Lot.

No outbuilding, or other building or structure shall be constructed, altered, or maintained on any Lot, other than those specified in the Pattern Book.



Permitted commercial buildings shall be only those specified in the Pattern Book.

#### **IV. BUILDING AREA**

No dwelling or other building shall be constructed on any Lot unless the design and location conforms with the specifications for the applicable building type specified in the Pattern Book. Dwellings and other buildings must be scaled to compliment the lot size, geometry and existing landscaping as well as neighboring structures where applicable.

#### **V. DESIGN AND CONSTRUCTION.**

All design elements of buildings on every Lot shall conform to the requirements stated in the Pattern Book, including, without limitation:

- A. All buildings, dwellings and Outbuildings shall be designed and constructed in accordance with one of the Architectural Patterns set forth in the Pattern Book and utilizing materials specified in the Pattern Book for the applicable Architectural Pattern.
- B. All building structures or improvements of any kind must be completed within twelve (12) months of the date of commencement of construction.
- C. The Association hereby delegates to the Architectural Review Board the authority to determine Compliance with the architectural standards of the Pattern Book. All appropriate Architectural Review Board Documents shall be submitted to the City of West Des Moines.
- D. Lighting Design Guidelines:
  - 1) The following reference guidelines from the Illuminating Engineering Society of North America (IESNA) shall be utilized as a basis for design when selecting and designing an exterior lighting system:
    - i. IESNA RP-8-00 “Roadway Lightning”
    - ii. IESNA RP-33-99 “Lightning for Exterior Environments”
    - iii. IESNA G-1-03 “Guideline on Security Lightning for People, Property, and Public Spaces”
  - 2) Commercial property parking areas shall be designed with the MAXIMUM lighting level as follows:
    - i. 5 foot-candle average
    - ii. 1 foot candle minimum
    - iii. 10-1 max:min
  - 3) All private commercial property shall extinguish 90% of their parking lot lighting by 11:00 p.m. unless the business uses a third shift or a larger workforce who work non-traditional house past midnight. All building

mounted area lighting or other lighting used for security lighting around the perimeter of the building may remain on from dusk to dawn.

- 4) All private commercial property shall utilize full cut-off optics, minimize lighting trespass from commercial zones to residential zones and use minimum required lighting levels and/or night-time curfews on parking lot lighting where businesses are not operational 24 hours a day. Minimize building floodlighting and utilize high performance optics to again minimize the amount of light either being reflected off of the façade or directed up into the sky.

#### **VI. TEMPORARY AND OTHER STRUCTURES; CERTAIN USES.**

No temporary building or structure shall be built or maintained on any Lot except those that conform with the guidelines in the Pattern Book.

#### **VII. FENCES**

No fences shall be built or maintained on any Lot unless they conform to the specifications set for in the Pattern Book and the plans for such fencing are reviewed and approved by the Association Board in advance of installation or construction. All fences must be maintained to installation quality.

No exterior dog runs shall be allowed in residential areas.

#### **VIII. RUBBISH CONTAINERS (RESIDENTIAL ONLY)**

On all Lots, rubbish containers shall conform with the guidelines in the Pattern Book.

#### **IX. LANDSCAPING**

Lot landscaping shall be the responsibility of the Owner and shall reflect one or more of the landscape patters recommended for the type of Lot in the Pattern Book. Additionally, the amount of lot landscaping specified in the Pattern Book shall be strictly adhered to by the Owner. Frontage street trees as shown on the final plat construction plans shall be included on the dwelling landscape plans and installed with the Lot landscaping or upon installation of the sidewalks. All landscaping must be installed within six (6) months from the completion of construction. All landscaping shall be maintained and replaced (as necessary) by the Owner in conformance with the standards of the Pattern Book.

The Owner shall keep the Lot free of debris and shall keep the grass mowed so that it does not exceed six inches in height.

All additional landscaping conditions shall conform with the guidelines in the Pattern Book.

#### **X. SIDEWALKS**

The purchaser of a Lot shall, at the purchaser's expense, install public sidewalks in accordance with the specifications of the City of West Des Moines and the Pattern Book. The installation and construction of the sidewalks shall be completed upon the earlier of: (i)

substantial completion of the improvements on said Lot; or (ii) one (1) year following the purchase of the Lot from the Declarant.

#### **XI. ARCHITECTURAL REVIEW**

11.01 The Architectural Review Board shall review plans and specifications for all proposed buildings, structures, outbuildings, and any such other requests as it relates to the Development Area. The Architectural Review Committee shall be responsible for matters covered by this Master Declaration which may not be covered by a separate declaration for those certain developments located within the Preserve. The Architectural Review Board of the Association and the Declarant shall have the right to delegate any responsibilities for the review and approval of plans to the Subassociation or neighborhood association through a separate declaration and shall have the right to approve any signage revisions under this Master Declaration.

#### **XII. EASEMENTS**

Easements for installation and maintenance of utilities and drainage facilities are reserved as shown on the recorded Official Plats of the Preserves or are reserved on separately recorded easements. The Owner and/or occupant of each Lot, jointly and severally, shall at the expense of such Owner and/or occupant, maintain, keep, and preserve that portion of the easement area within the Lot at all times in good repair and condition and shall neither erect nor permit erection of any building, structure or other improvement of any kind within said easement areas (except customary and traditional ground cover) which might interfere in any way with the use, maintenance, replacement, inspection or patrolling of any of the utility services and drainage facilities within such easement areas. The Owner and/or occupant of each Lot, jointly and severally, shall at the expense of such Owner and/or occupant, preserve and maintain any berm and/or swale constructed for drainage purposes to accomplish the purposes for which it was constructed.

#### **XIII. NUISANCES**

No noxious or offensive activity or odors shall be permitted on or to escape from any Lot, nor shall anything be done thereon which is or may become what a reasonable person would consider to be a genuine annoyance or a genuine nuisance, either temporarily or permanently.

#### **XIV. SIGNS (RESIDENTIAL ONLY)**

No sign of any kind shall be placed, exposed to view or permitted to remain on any Lot or any street adjacent thereto unless otherwise outlined in the Pattern Book.

#### **XV. UTILITIES**

All utility connection facilities and services shall be underground. No individual water supply system or individual sewage disposal system shall be permitted on any Lot.

Declarant reserves the right to provide exclusive access to providers of telecommunications, cable, internet, and other utilities to The Preserves.

## **XVI. ANTENNAS**

No exterior towers or antennas of any kind shall be constructed, modified, or permitted on any Lot, except as herein specifically permitted. Customary television or radio antennas not exceeding five (5) feet in height shall be permitted if attached directly to either the dwelling or garage. A satellite dish (or similar structure) shall be permitted in a size and manner as provided by rules of the Association Board.

## **XVII. MAINTENANCE**

The Owner and/or occupant of each Lot shall jointly and severally be responsible to keep the Lot free of trash, weeds and debris and to keep the lawn and landscaping well maintained and healthy. The Owner and/or occupant of each Lot shall jointly and severally be responsible to maintain the exterior of any dwelling, the driveway, fence, screening and all other improvements.

## **XVIII. CERTAIN ANIMALS PROHIBITED**

No animals, livestock or poultry of any kind shall be raised, bred or kept on any residential Lot unless those permitted by any amendment to this Master Declaration or by separate declaration for a specific plat.

## **XIX. SURFACE WATER**

The topography of the Lot is such that surface water may flow from certain Lots onto other Lots. In regard to all matters concerning surface water, each Lot shall be subject to and benefited by such easements as may exist for the flowage of surface water under the law of the State of Iowa, as may be in effect from time to time; and all owners shall have such rights and obligations with respect thereto as may be provided by such law. The Pattern Book provides guidelines for those parties interested in this matter.

## **XX. COVENANT FOR ASSESSMENTS**

### **A. Creation of the Lien and Personal Obligation of Assessments.**

The Declarant, for each Lot owned within The Preserve Estates Property, and improved for which a certificate of occupancy has been issued, hereby covenants, and each other Owner of any Lot by acceptance of a deed thereof, whatever or not it shall be so expressed in such deed, is deemed to covenant and agrees to pay the Association: (i) regular assessments or charges, and (ii) special assessments for capital improvements and operating deficits, and other special assessments as provided in this Master Declaration; such assessments to be established and collected as hereinafter provided. The regular and special assessments, together with interest, costs, and reasonable attorney's fees, shall be a charge on the land and shall be a continuing lien upon the Lot against which each such assessment is made senior to all liens except a first mortgage of record, municipal utilities, and any ad valorem taxes. Each such assessment, together with interest, costs, and reasonable attorney's fees, shall also be the personal obligation of the person who was the owner of such Lot at the time when the Assessment fell due. The personal obligation for delinquent assessments shall not pass to his successors in title unless expressly assumed by them.

B. Purpose of Assessment.

The assessments levied by the Association shall be used exclusively to promote the health, safety, and welfare of the residents and/or occupants in the Plat and for the improvement and maintenance of the Common Areas and for other purposes specifically provided herein; PROVIDED, HOWEVER, that Declarant and/or the Association reserves the right to include Common Areas outside the boundaries of the Development Area. In addition, the regular assessment shall include repayment of sums advanced by the Declarant on behalf of the Association.

C. Special Assessments for Capital Improvements and Operating Deficits.

In addition to the regular assessments authorized above, the Association may levy a special assessment for the purpose of defraying, in whole or in part, the cost of any construction, reconstruction, repair or replacement of capital improvement, which the Association required to maintain or for operating deficits which the Association may from time to time incur.

D. Date of Commencement of Regular Assessments: Due Dates:

The regular assessments provided for herein shall commence as to each respective Lot on the first day of the first month following the date of conveyance to an Owner of a Lot with completed living unit constructed thereon and for which a certificate of occupancy has been issued. Lots which do not have completed living units constructed thereon and for which certificates of occupancy have not been issued, shall be exempt from assessments. The due dates for all assessments shall be established by the Board of Directors. The Association shall, upon demand, and for a reasonable charge, furnish a certificate in a recordable form signed by an officer of the Association setting forth whether the assessments on a specified Lot have been paid. A properly executed certificate from the Association regarding the status of assessments on a Lot shall be binding upon the Association as of the date of its issuance.

E. Effect of Nonpayment of Assessments: Remedies of the Association.

Any assessment not paid within thirty (30) days after the due date shall, in addition to being a lien upon such Owner's Lot, bear interest from the due date at the rate of 15% per annum or at the highest rate allowed by Iowa law, whichever is lower. The Association may bring an action at law against the Owner personally obligated to pay the same, or foreclose the lien against the Lot in the manner provided for foreclosure of a mortgage, or both, and there shall be added to the amount of such assessment the cost of preparing and filing the petition in such action, including reasonable attorney's fees. No Owner may waive or otherwise escape liability for the assessments provided for herein by abandonment of his Lot.

F. Subordination of Assessments Liens.

If any Lot subject to a lien created by any provision in this Master Declaration shall be subject to the lien of a first mortgage record: (i) the foreclosure of any lien created by anything set forth in this Master Declaration shall not operate to affect or impair the lien of such mortgage; and (ii) the foreclosure of the lien of such mortgage or the acceptance of a deed in lieu of the foreclosure by the mortgagee, shall not operate to affect or impair the lien except that assessment liens, if any, as shall have come due up to the expiration of the applicable

redemption period and issuance of a sheriff's deed resulting from a decree of foreclosure or the appointment of a receiver in foreclosure proceedings or the acceptance of the deed in lieu of foreclosure shall be subordinate to the lien of the mortgage, with foreclosure-purchaser and purchasers therefrom taking title free of assessments, if any, that have come due up to the expiration of the applicable redemption period and issuance of a sheriff's deed resulting from a decree of foreclosure or the appointment of a receiver in a foreclosure proceedings or deed given in lieu of foreclosure, but subject to assessment liens that shall have come due subsequent to the expiration of the applicable redemption period and issuance of a sheriff's deed resulting from a decree of foreclosure or the appointment of a receiver in foreclosure proceedings or the acceptance of a deed in lieu of foreclosure. All assessment liens as shall have come due up to the expiration of the applicable redemption period and issuance of a sheriff's deed resulting from a decree of foreclosure or the appointment of a receiver in foreclosure proceedings or the acceptance of a deed in lieu of foreclosure and have not been paid shall be deemed to be an expense of the Association, but this shall not derogate the Association's right to collect said sums from the defaulting owner personally.

**XXI. ENFORCEMENT AND MEMBER RIGHTS OF COVENANTS**

This Master Declaration shall be deemed to run with the land, and the Declarant and/or the Owner of any Lot may bring an action in any court of competent jurisdiction to enforce this Declaration of Covenants, Conditions and Restrictions and enjoin its violation or for damages for the breach thereof, or for any other remedy or combination of remedies recognized at law or in equity. The members of the Association shall be each of the separate boards of the subassociation or neighborhood associations within The Preserve. Every lot owner in the Association shall only be a member of the Association through the association for their specific development. Each separate association within The Preserve shall get a pro-rata share of the Association votes under this Master Declaration based on the number of acres covered by the specific development (numerator) and the number of acres covered by this Master Declaration (denominator). Each subassociation shall get one designated representative on the Association Board to represent that subassociation.

**XXII. AMENDMENTS OF COVENANTS**

This Master Declaration be amended from time to time with approval of the Owners. Said Approval shall be given by the affirmative vote of not less than two-thirds (2/3) of the Owners. The Owner of each Lot (or the joint Owners of a single Lot in the aggregate) shall be entitled to cast one vote on account of each Lot owned. Provided, however, until twelve (12) months following the date on which the Declarant has sold all of the Lots, it may make amendments or modifications to this Master Declaration of Covenants, Conditions and Restrictions without the consent of any other Owners, Subassociation or any other party. Such amendments or modifications by the Declarant shall be effective only after all other Owners are provided with a copy of the amendment or modification by ordinary mail and the amendment or modification has been filed with the Dallas County Recorder.

**XXIII. PERIOD OF COVENANTS**

The easements granted in and the obligations created by or pursuant to Article XII of this Master Declaration or granted in any other Section of this Master Declaration, any other provisions of this Master Declaration expressly incorporated in Article XII or such other

Section of this Master Declaration to the extent applicable to such easements and obligations, and any other covenants, indentures, restrictions and reservations of this Master Declaration that are reasonably or necessarily incidental to the benefit or burden of such easement rights and obligations, shall continue in perpetuity, unless sooner modified or terminated as provided herein.

Except as provided in the preceding paragraph of this Section, the covenants, indentures, restrictions and reservations this Master Declaration shall be for an initial term of twenty (20) years, and shall automatically renew for successive terms of ten (10) years each.

**XXIV. ENFORCEMENT AND WAIVER**

A. In the event that any one or more of the foregoing covenants, conditions or restrictions shall be declared for any reason by a court of competent jurisdiction to be null and void, such judgement or decree shall not in any manner whatsoever affect, modify, change, abrogate, or nullify any of the covenants, conditions and restrictions not so expressly held to be void, which shall continue unimpaired and in full force and effect.

B. Wherever there is a conflict between this Master Declaration and the zoning ordinance of the City of West Des Moines, the more restrictive provision shall be binding.

**XXV. DISCLAIMER**

Declarant may at anytime by written instrument filed with the Dallas County Recorder, disclaim their rights and powers hereunder and thereafter it shall have no rights or responsibilities hereunder. Declarant shall have no liability in or for damages of any sort to any Owner, or nay lessee or occupant of any Lot, or otherwise to any person for any exercise or failure to exercise any right (or duty or obligation, if any) of Declarant hereunder, for the making of an amendment or modification hereto by Declarant for the granting of approval or withholding of approval required or permitted under the terms of this Master Declaration or in any other manner arising herefrom. Provided however, any Owner may exercise any rights such Owner may have against Declarant or otherwise seek to enforce the provisions of this Master Declaration against Declarant by an action in equity for specific performance or injunctive relief to which Declarant shall be subject. The remedies of specific performance and injunctive relief shall be the only remedies against Declarant hereunder, for the making of an amendment or modification hereto by Declarant, for the granting of approval or withholding of approval required or permitted under the terms of this Master Declaration or for other matters arising herefrom, all other remedies being expressly waved. Notwithstanding the foregoing, the rights and powers of the Declarant hereunder shall be deemed to have been disclaimed by Declarant five (5) years following the date on which Declarant conveys the last Lot it owns in the Property, and thereafter enforcement of this Master Declaration may be carried out exclusively by the Owners as provided in Article XIX, above.

This Master Declaration of Covenants, Conditions and Restrictions, was made the date first written above by the Declarant.

[SIGNATURES ON THE FOLLOWING PAGE]

**RACCOON RIVER LAND CO., L.L.C.**  
an Iowa limited liability company

By: William C. Knapp, L.C.  
an Iowa limited liability company  
Managing Member

By: Gerard D. Neugent  
Gerard D. Neugent, Manager

By: RACCOON RIVER INVESTORS, LLC  
Managing Member

By: JSC TRUST  
Member

By: Paul D. Hayes  
Paul D. Hayes, Trustee

**ACKNOWLEDGEMENTS**

State of Iowa            )  
                                  )ss:  
County of Polk         )

This record was acknowledged before me on November 6, 2020 by Gerard D. Neugent, Manager of William C. Knapp, L.C., Member of Raccoon River Land Co., L.L.C.

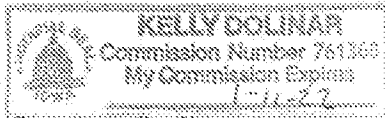

(Stamp or Seal)

Kelly Dolinar  
Notary Public

State of Iowa            )  
                                  )ss:  
County of Polk         )

This record was acknowledged before me on November 6, 2020 by Paul D. Hayes, Trustee of JSC Trust, Member in Raccoon River Investors, LLC, Member of Raccoon River Land Co., L.L.C.

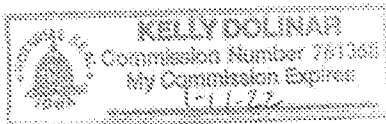

(Stamp or Seal)

Kelly Dolinar  
Notary Public



EXHIBIT A

[SEE FOLLOWING PAGE]

**THE PRESERVE**  
**P.U.D. REZONING**  
**SKETCH-AMENDMENT I**  
 WEST DES MOINES, IOWA  
 DALLAS & MADISON COUNTY

City Engineering Consultants, Inc.  
 2440 68th Street, Unit 12, Des Moines, Iowa 50322  
 515 276-1884 Fax: 515-276-7094 email@cec.com



THE PRESERVE  
 WEST DES MOINES, IOWA, DALLAS & MADISON COUNTY  
 P.U.D. REZONING SKETCH-AMENDMENT I

02  
 OF 02

**CURVE DATA**

STATION	PIVOT	ANGLE	LENGTH	CHORD	CHORD BEARING
1+00.00	1+00.00	90.00	100.00	100.00	S 00° 00' 00" W
1+10.00	1+10.00	90.00	100.00	100.00	S 00° 00' 00" W
1+20.00	1+20.00	90.00	100.00	100.00	S 00° 00' 00" W
1+30.00	1+30.00	90.00	100.00	100.00	S 00° 00' 00" W
1+40.00	1+40.00	90.00	100.00	100.00	S 00° 00' 00" W
1+50.00	1+50.00	90.00	100.00	100.00	S 00° 00' 00" W
1+60.00	1+60.00	90.00	100.00	100.00	S 00° 00' 00" W
1+70.00	1+70.00	90.00	100.00	100.00	S 00° 00' 00" W
1+80.00	1+80.00	90.00	100.00	100.00	S 00° 00' 00" W
1+90.00	1+90.00	90.00	100.00	100.00	S 00° 00' 00" W
2+00.00	2+00.00	90.00	100.00	100.00	S 00° 00' 00" W
2+10.00	2+10.00	90.00	100.00	100.00	S 00° 00' 00" W
2+20.00	2+20.00	90.00	100.00	100.00	S 00° 00' 00" W
2+30.00	2+30.00	90.00	100.00	100.00	S 00° 00' 00" W
2+40.00	2+40.00	90.00	100.00	100.00	S 00° 00' 00" W
2+50.00	2+50.00	90.00	100.00	100.00	S 00° 00' 00" W
2+60.00	2+60.00	90.00	100.00	100.00	S 00° 00' 00" W
2+70.00	2+70.00	90.00	100.00	100.00	S 00° 00' 00" W
2+80.00	2+80.00	90.00	100.00	100.00	S 00° 00' 00" W
2+90.00	2+90.00	90.00	100.00	100.00	S 00° 00' 00" W
3+00.00	3+00.00	90.00	100.00	100.00	S 00° 00' 00" W
3+10.00	3+10.00	90.00	100.00	100.00	S 00° 00' 00" W
3+20.00	3+20.00	90.00	100.00	100.00	S 00° 00' 00" W
3+30.00	3+30.00	90.00	100.00	100.00	S 00° 00' 00" W
3+40.00	3+40.00	90.00	100.00	100.00	S 00° 00' 00" W
3+50.00	3+50.00	90.00	100.00	100.00	S 00° 00' 00" W
3+60.00	3+60.00	90.00	100.00	100.00	S 00° 00' 00" W
3+70.00	3+70.00	90.00	100.00	100.00	S 00° 00' 00" W
3+80.00	3+80.00	90.00	100.00	100.00	S 00° 00' 00" W
3+90.00	3+90.00	90.00	100.00	100.00	S 00° 00' 00" W
4+00.00	4+00.00	90.00	100.00	100.00	S 00° 00' 00" W
4+10.00	4+10.00	90.00	100.00	100.00	S 00° 00' 00" W
4+20.00	4+20.00	90.00	100.00	100.00	S 00° 00' 00" W
4+30.00	4+30.00	90.00	100.00	100.00	S 00° 00' 00" W
4+40.00	4+40.00	90.00	100.00	100.00	S 00° 00' 00" W
4+50.00	4+50.00	90.00	100.00	100.00	S 00° 00' 00" W
4+60.00	4+60.00	90.00	100.00	100.00	S 00° 00' 00" W
4+70.00	4+70.00	90.00	100.00	100.00	S 00° 00' 00" W
4+80.00	4+80.00	90.00	100.00	100.00	S 00° 00' 00" W
4+90.00	4+90.00	90.00	100.00	100.00	S 00° 00' 00" W
5+00.00	5+00.00	90.00	100.00	100.00	S 00° 00' 00" W
5+10.00	5+10.00	90.00	100.00	100.00	S 00° 00' 00" W
5+20.00	5+20.00	90.00	100.00	100.00	S 00° 00' 00" W
5+30.00	5+30.00	90.00	100.00	100.00	S 00° 00' 00" W
5+40.00	5+40.00	90.00	100.00	100.00	S 00° 00' 00" W
5+50.00	5+50.00	90.00	100.00	100.00	S 00° 00' 00" W
5+60.00	5+60.00	90.00	100.00	100.00	S 00° 00' 00" W
5+70.00	5+70.00	90.00	100.00	100.00	S 00° 00' 00" W
5+80.00	5+80.00	90.00	100.00	100.00	S 00° 00' 00" W
5+90.00	5+90.00	90.00	100.00	100.00	S 00° 00' 00" W
6+00.00	6+00.00	90.00	100.00	100.00	S 00° 00' 00" W
6+10.00	6+10.00	90.00	100.00	100.00	S 00° 00' 00" W
6+20.00	6+20.00	90.00	100.00	100.00	S 00° 00' 00" W
6+30.00	6+30.00	90.00	100.00	100.00	S 00° 00' 00" W
6+40.00	6+40.00	90.00	100.00	100.00	S 00° 00' 00" W
6+50.00	6+50.00	90.00	100.00	100.00	S 00° 00' 00" W
6+60.00	6+60.00	90.00	100.00	100.00	S 00° 00' 00" W
6+70.00	6+70.00	90.00	100.00	100.00	S 00° 00' 00" W
6+80.00	6+80.00	90.00	100.00	100.00	S 00° 00' 00" W
6+90.00	6+90.00	90.00	100.00	100.00	S 00° 00' 00" W
7+00.00	7+00.00	90.00	100.00	100.00	S 00° 00' 00" W
7+10.00	7+10.00	90.00	100.00	100.00	S 00° 00' 00" W
7+20.00	7+20.00	90.00	100.00	100.00	S 00° 00' 00" W
7+30.00	7+30.00	90.00	100.00	100.00	S 00° 00' 00" W
7+40.00	7+40.00	90.00	100.00	100.00	S 00° 00' 00" W
7+50.00	7+50.00	90.00	100.00	100.00	S 00° 00' 00" W
7+60.00	7+60.00	90.00	100.00	100.00	S 00° 00' 00" W
7+70.00	7+70.00	90.00	100.00	100.00	S 00° 00' 00" W
7+80.00	7+80.00	90.00	100.00	100.00	S 00° 00' 00" W
7+90.00	7+90.00	90.00	100.00	100.00	S 00° 00' 00" W
8+00.00	8+00.00	90.00	100.00	100.00	S 00° 00' 00" W
8+10.00	8+10.00	90.00	100.00	100.00	S 00° 00' 00" W
8+20.00	8+20.00	90.00	100.00	100.00	S 00° 00' 00" W
8+30.00	8+30.00	90.00	100.00	100.00	S 00° 00' 00" W
8+40.00	8+40.00	90.00	100.00	100.00	S 00° 00' 00" W
8+50.00	8+50.00	90.00	100.00	100.00	S 00° 00' 00" W
8+60.00	8+60.00	90.00	100.00	100.00	S 00° 00' 00" W
8+70.00	8+70.00	90.00	100.00	100.00	S 00° 00' 00" W
8+80.00	8+80.00	90.00	100.00	100.00	S 00° 00' 00" W
8+90.00	8+90.00	90.00	100.00	100.00	S 00° 00' 00" W
9+00.00	9+00.00	90.00	100.00	100.00	S 00° 00' 00" W
9+10.00	9+10.00	90.00	100.00	100.00	S 00° 00' 00" W
9+20.00	9+20.00	90.00	100.00	100.00	S 00° 00' 00" W
9+30.00	9+30.00	90.00	100.00	100.00	S 00° 00' 00" W
9+40.00	9+40.00	90.00	100.00	100.00	S 00° 00' 00" W
9+50.00	9+50.00	90.00	100.00	100.00	S 00° 00' 00" W
9+60.00	9+60.00	90.00	100.00	100.00	S 00° 00' 00" W
9+70.00	9+70.00	90.00	100.00	100.00	S 00° 00' 00" W
9+80.00	9+80.00	90.00	100.00	100.00	S 00° 00' 00" W
9+90.00	9+90.00	90.00	100.00	100.00	S 00° 00' 00" W

**LEGEND**

- PROPERTY BOUNDARY
- - - - - SECONDARY BOUNDARY
- ALLEY
- SIDE FOR MARKET

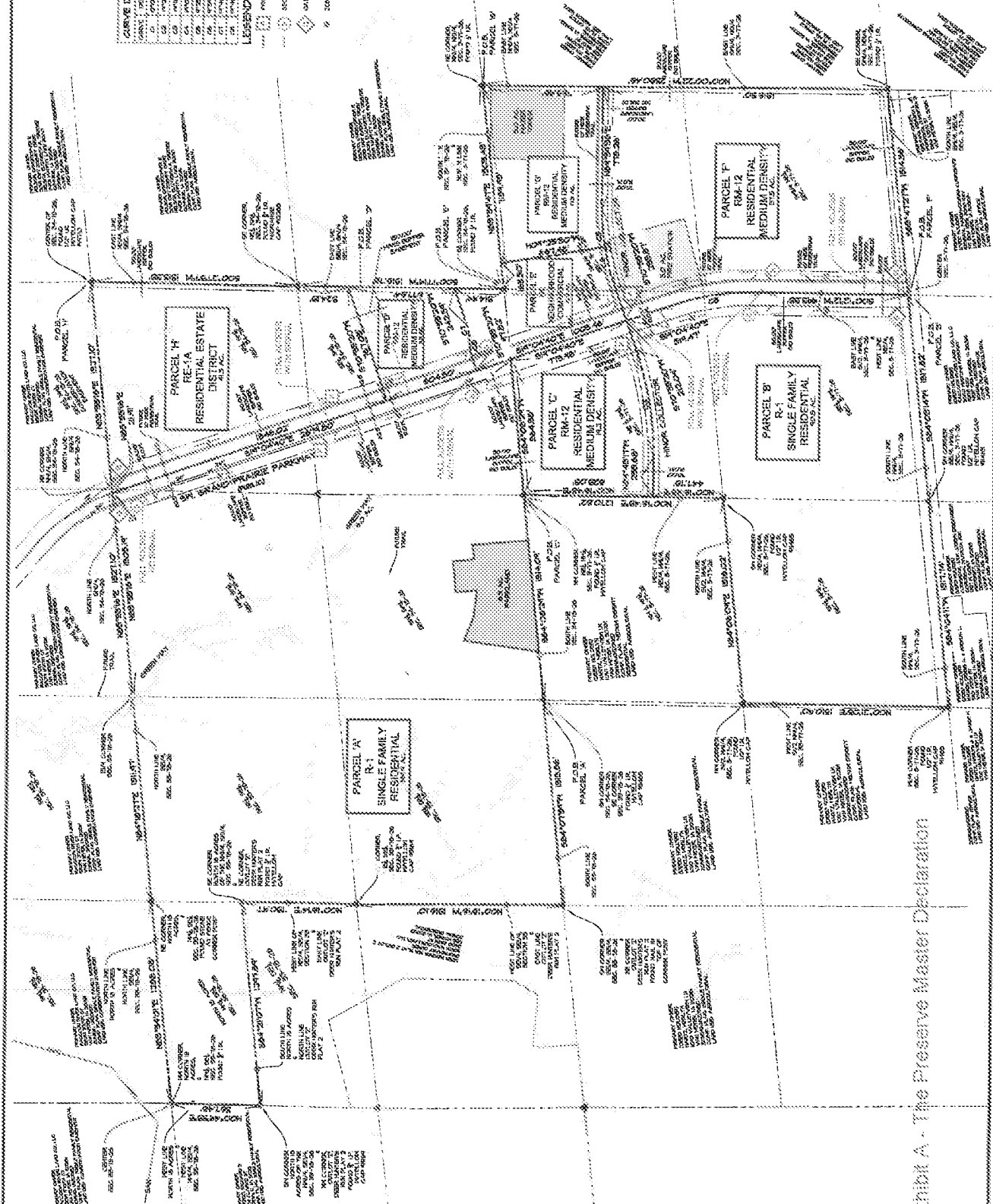

Exhibit A - The Preserve Master Declaration

SCALE: 1" = 60'  
 NORTH  
 1" = 60' PRINTED ON 22" x 34" SHEET  
 1" = 60' PRINTED ON 11" x 17" SHEET